



88046206

**DESIGN TECHNOLOGY  
STANDARD LEVEL  
PAPER 3**

Thursday 18 November 2004 (morning)

1 hour

School code

--	--	--	--	--	--

Candidate code

--	--	--	--	--	--

---

**INSTRUCTIONS TO CANDIDATES**

- Write your school code and candidate code in the boxes above.
- Do not open this examination paper until instructed to do so.
- Answer all of the questions from two of the Options in the spaces provided. You may continue your answers on answer sheets. Write your school code and candidate code on each answer sheet, and attach them to this examination paper and your cover sheet using the tag provided.
- At the end of the examination, indicate the letters of the Options answered in the candidate box on your cover sheet and indicate the number of answer sheets used in the appropriate box on your cover sheet.

**Option A – Raw Material to Final Product**

**A1.** Figures A1 and A2 below show some jewellery. The beads making up the bracelet in **Figure A1** are made of ground glass pieces. The beads in **Figure A2** are made of hardwood. The beads are threaded on nylon threads and the clasps are made of stainless steel.

**Figure A1: Bracelet made of ground glass beads**     **Figure A2: Hardwood bead bracelet**



(a) Explain how nylon threads are manufactured from petroleum. [3]

.....  
.....  
.....  
.....  
.....

(b) List **two** characteristics of nylon which make it suitable for threading the beads on to form the bracelets. [2]

.....  
.....  
.....  
.....

**A2.** Outline **one** reason for finishing wood for use in the jewellery. [2]

.....  
.....  
.....  
.....

**A3.** Outline **one** reason why stainless steel is a suitable material for the manufacture of the clasps. [2]

.....  
.....  
.....  
.....

**A4.** Discuss the importance of gaining public acceptability in the commercial success of new foods, *e.g.* mycoprotein. [6]

.....  
.....  
.....  
.....  
.....  
.....  
.....  
.....  
.....  
.....  
.....  
.....  
.....  
.....  
.....  
.....  
.....  
.....  
.....  
.....  
.....

**Option B – Microstructures and Macrostructures**

**B1.** **Figure B1** shows a new type of body armour that incorporates Kevlar® (aramid) fibres. The body armour is used by police, armed forces and prison staff. Extra fine Kevlar® fibres are woven into a fabric layer. The layers are then combined with a special resin to produce a laminated fabric. The fibres absorb and dissipate the energy of penetration by a bullet or a stabbing instrument. The resin stops the fibres being pushed apart and the body armour being penetrated (see **Figure B2**). The body armour is lighter, more flexible and more comfortable than earlier products and has been shown to be better in performance tests.

**Figure B1: New style body armour**



**Figure B2: The laminated fabric showing the fibres and the resin**

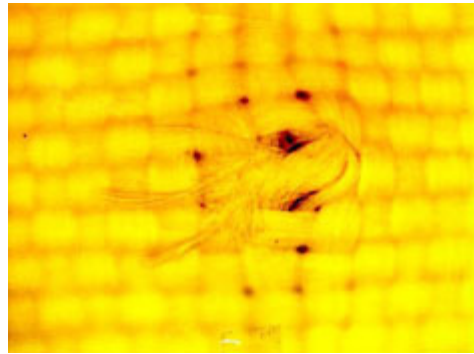

(a) Describe the structure of Kevlar® fibres. [2]

.....  
.....  
.....  
.....

(b) List **two** mechanical properties of Kevlar® fibres that make it suitable for application in the production of laminated fibre for the body armour. [2]

.....  
.....

**B2.** Describe a covalent bond. [2]

.....  
.....  
.....  
.....

**B3.** Explain melting in terms of the behaviour of particles in a solid. *[3]*

.....  
.....  
.....  
.....

**B4.** Explain how grain size can be controlled and modified by the rate of cooling of a molten metal. *[6]*

.....  
.....  
.....  
.....  
.....  
.....  
.....  
.....  
.....  
.....  
.....  
.....  
.....  
.....  
.....  
.....  
.....  
.....  
.....  
.....  
.....

**Option C – Appropriate Technologies**

**C1.** An increasing number of countries are creating laws threatening penalties to encourage companies to design products in more environmentally friendly ways, particularly in relation to waste management. The laws are called “Extended Producer Responsibility” or “Take-Back” laws and will force manufacturers or importers to be involved in the disposal of products. Increased recycling will reduce the total quantity of waste going into landfill sites or being burnt. Producers will be responsible for taking back and recycling electrical and electronic equipment. Consumers will be able to return their equipment free of charge.

**Figure C1: Take-Back laws extend producer responsibility throughout product life cycle.**

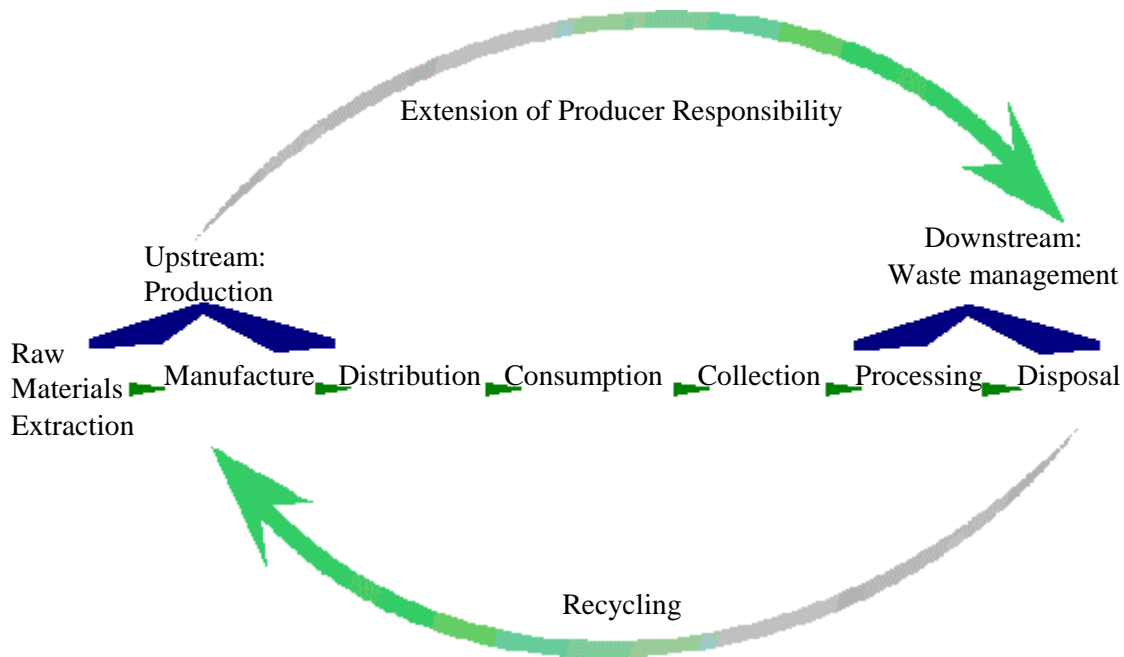

[Source: <http://www.cpa.most.org.pl/cpb4.html>]

(a) Outline **one** issue that contributes to the feasibility of recycling. [2]

.....

.....

.....

.....

(b) Outline how consumer attitudes towards sustainability have created a “market pull” situation. [2]

.....

.....

.....

.....

*(This question continues on the following page)*

*(Question C1 continued)*

- (c) Explain how Extended Producer Responsibility legislation will contribute to a reduction in the rate of exploitation of resources. [3]

.....

.....

.....

.....

- C2.** List **two** characteristics of an appropriate technology. [2]

.....

.....

.....

.....

- C3.** Explain **two** ways in which products can be designed to make them easier to deal with when they are returned to the company when they are no longer wanted by the purchaser. [6]

.....

.....

.....

.....

.....

.....

.....

.....

.....

.....

.....

.....

.....

.....

.....

.....

.....

.....

.....

.....

.....

.....

.....

**Option D – Food Technology**

**D1.** **Figure D1** is a photograph of a tomato spoiled by microbial growth. **Figure D2** shows a can of tomatoes.

**Figure D1: Photograph of rotten tomato**

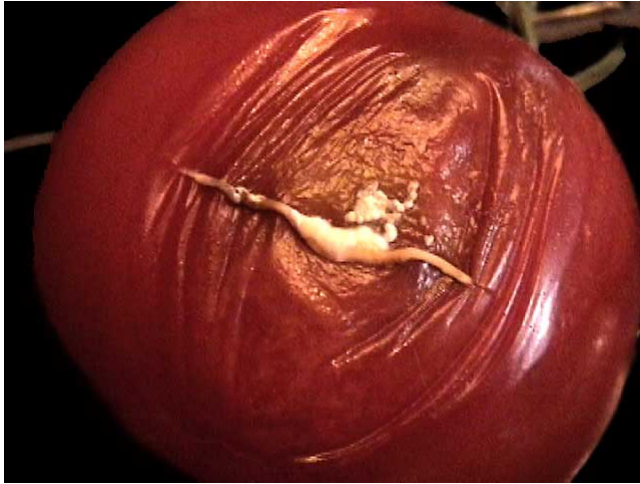

**Figure D2: Can of tomatoes**



(a) List **two** factors that influence the ease of microbial spoilage. [2]

.....  
.....  
.....  
.....

(b) Describe how canning extends the safe storage life of tomatoes. [2]

.....  
.....  
.....  
.....

(c) Outline how canning of tomatoes influences **one** organoleptic property of tomatoes. [2]

.....  
.....  
.....  
.....



**D2.** Explain **one** way in which on-farm processing of food can enhance farm sustainability. [3]

.....  
.....  
.....

**D3.** Explain how nutritional requirements and preferred foods change as a person matures into adulthood. [6]

.....  
.....  
.....  
.....  
.....  
.....  
.....  
.....  
.....  
.....  
.....  
.....  
.....  
.....  
.....  
.....  
.....  
.....  
.....  
.....  
.....

**Option E – Computer-aided Design, Manufacture and Production**

**E1.** **Table E1** lists five different mass customization strategies relating to the extent of customer involvement in the design of the product. In *Design to Order* the customer is involved in the design of the product whereas, in *Post Delivery* modifications are made to the product after delivery.

BespokeComputerSolutions.com is a computer company which holds a stock of computer components and maintains a web site enabling it to develop a computer in response to an individual customer’s specification.

A second company, JustForYourDolls.com, also runs a web site on which from a series of menus, a customer can design a doll with hair colour, eye colour, *etc.* of the customer’s choice. The appropriate components are produced and the doll assembled, packaged and delivered.

**Table E1: Mass Customization Strategies**

Strategy	Description
Post Delivery	Products are stocked at retail outlets. The design of the product facilitates customer involvement and modifications after delivery.
Deliver to Order	Products are assembled and stocked. The product is then packaged and distributed in response to individual customer delivery requirements.
Assemble to Order	A database of raw material and components held in stock is maintained. Assembly of the product commences once an order is placed.
Fabricate to Order	The manufacturer holds only raw materials inventory. The company responds to individual customer requirements which enable product customization prior to assembly.
Design to Order	No inventory is held. The customer is involved at the design stage.

(a) Identify which mass customization strategy is being used by BespokeComputerSolutions.com. [2]

.....

.....

.....

.....

(b) Identify which mass customization strategy is being used by JustForYourDolls.com. [2]

.....

.....

.....

.....

*(This question continues on the following page)*

(Question E1 continued)

- (c) Explain how mass customization transforms the relationship between the manufacturer and the consumer. [3]

.....

.....

.....

.....

.....

- E2.** Outline **one** way in which virtual reality would help consumers using JustForYourDolls.com. [2]

.....

.....

.....

.....

- E3.** Explain **one** advantage and **one** disadvantage of Just-in-time (JIT) for BespokeComputerSolutions.com. [6]

.....

.....

.....

.....

.....

.....

.....

.....

.....

.....

.....

.....

.....

.....

.....

.....

.....

.....

.....

.....

.....

.....

.....

.....

**Option F – Invention, Innovation and Design**

**F1.** **Figure F1** shows the prototype for a new refrigerator-computer that contains a computer and has a computer display screen mounted in its door. The display screen uses touch screen technology. As well as standard computer programmes, the computer runs a database on which the user can maintain a record of the refrigerator contents including the sell-by dates and consume-by dates of each item.

**Figure F1: Refrigerator-computer**



(a) Outline **one** reason why the refrigerator-computer in **Figure F1** is likely to have been developed by a team of designers rather than a lone inventor. [2]

.....  
.....  
.....  
.....

(b) List **two** factors that might result in the refrigerator-computer in **Figure F1** failing to reach the market place. [2]

.....  
.....  
.....  
.....

*(This question continues on the following page)*

(Question F1 continued)

- (c) Explain why it would be difficult to determine whether market pull or technology push was the impetus for the design of the refrigerator-computer in **Figure F1**. [3]

.....  
.....  
.....  
.....  
.....

- F2.** Outline **one** benefit of adopting a pioneering corporate strategy for the company introducing the refrigerator-computer. [2]

.....  
.....  
.....  
.....

- F3.** Explain **two** criteria relevant to a proactive environmental policy for the refrigerator manufacturing company. [6]

.....  
.....  
.....  
.....  
.....  
.....  
.....  
.....  
.....  
.....  
.....  
.....  
.....  
.....  
.....  
.....  
.....  
.....  
.....  
.....  
.....  
.....  
.....  
.....  
.....

**Option G – Health by Design**

**G1.** **Figure G1** shows a cross-section of the human eye receiving light from a distant object.

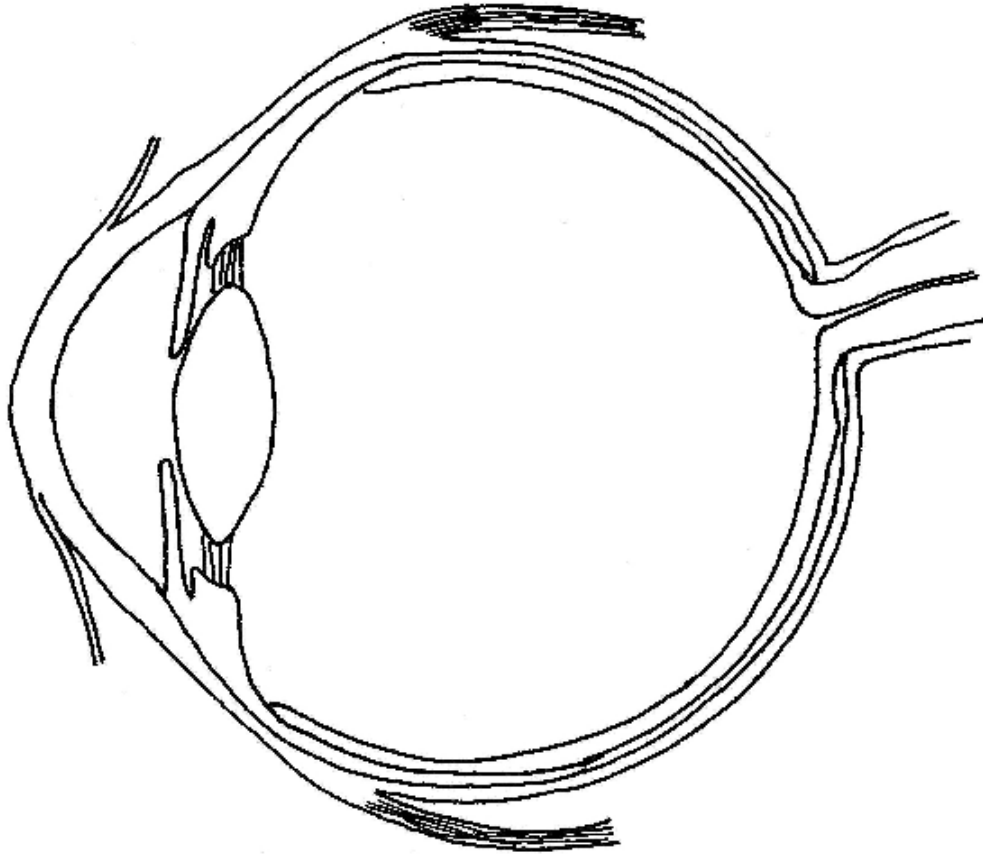

(a) Define *hypermetropia*. [1]

.....  
.....

(b) Annotate **Figure G1** to show what happens to the light from a distant object in hypermetropia. [1]

(c) Describe how hypermetropia can be corrected with a spectacle lens. [2]

.....  
.....  
.....

*(This question continues on the following page)*

*(Question G1 continued)*

- (d) Explain how spectacle wearers have benefited from the development of high refractive index glasses. [3]

.....

.....

.....

.....

.....

- G2. Outline **one** situation in which designers can benefit from adopting a user-centred design strategy. [2]

.....

.....

.....

.....

- G3. Discuss the significance of both the concepts of planned obsolescence and of reuse in the context of hearing aids. [6]

.....

.....

.....

.....

.....

.....

.....

.....

.....

.....

.....

.....

.....

.....

.....

.....

.....

.....

.....

.....

.....

.....

.....

.....

.....

.....

**Option H – Electronic Products**

**H1.** Figure H1 shows the performance characteristics of a thermistor.

**Figure H1: Performance characteristics of a thermistor**

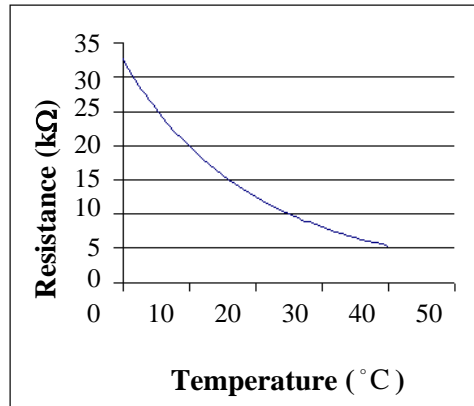

**Figure H2** is the incomplete circuit for a fish tank heater. The heater which is required to turn on to heat the water when the temperature falls below 25 °C.

**Figure H2: Incomplete circuit for a fish tank heater**

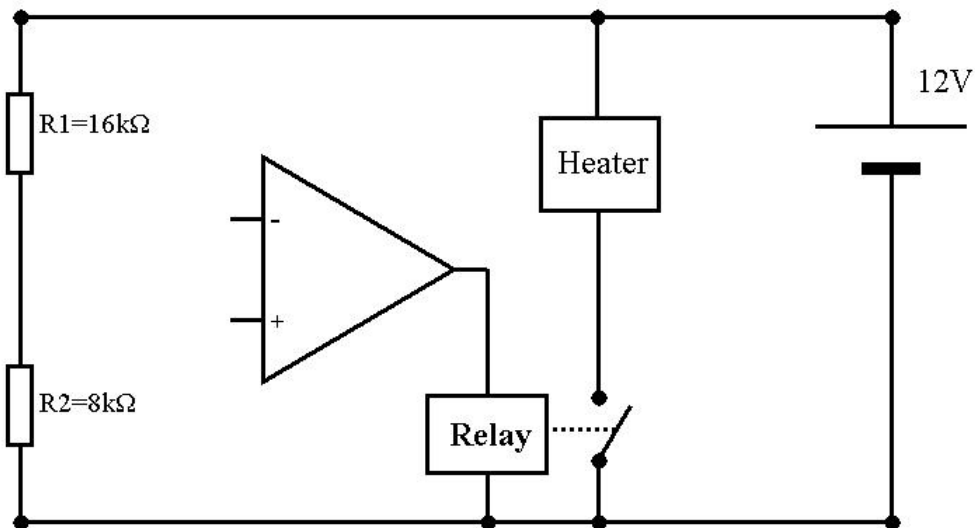

(a) Annotate Figure H2 to explain how you would complete the circuit using a thermistor and a fixed value resistor (do not select a value for the resistor at this point) so that it operates as a comparator circuit and the fish tank heater would turn on when the temperature of the water is less than 25 °C. [3]

(b) Identify a value for the fixed value resistor so that the circuit operates to turn the fish tank heater on at temperatures below 25 °C. [2]

.....

.....

.....

*(This question continues on the following page)*



